

Note 63 : RÖMER et DOPPLER

VIENNOT L. & LEROY J.L. (2004) DOPPLER and RÖMER: what do they have in common? *Physics Education*, **39** (3), 273-280.

This is an author-created, un-copyedited version of an article accepted for publication in *Physics Education*. IOP Publishing Ltd is not responsible for any errors or omissions in this version of the manuscript or any version derived from it. The definitive publisher-authenticated version is available online at <http://iopscience.iop.org/0031-9120/39/3/004>

Voir l'article ci-après.

Doppler and Römer: what do they have in common?

Laurence Viennot ¹ & Jean Luc Leroy-Bury ^{1,2}

¹Laboratoire de didactique des sciences Université Denis Diderot (Paris 7), FR

²Lycée N-D de Bury, Margency, FR

Introduction

Physics is, *par excellence*, the science which aims at a unified description of phenomena. Of course, we have to be careful not to claim that physics encompasses all aspects of human life; far from it. But so far as much of the material world is concerned, physics is a remarkably efficient description of what happens: efficient because highly synthetic and predictive.

Such a statement is commonplace, but it is not so easy to convey this message to students of all ages. Indeed, many factors induce us, as teachers, to present a rather fragmented view of science. In practice this is often unavoidable, for obvious reasons, but the question is to how to manage the teaching constraints so as at least sometimes to present a larger and more cohesive vision. Can we at least to some extent promote the idea that *coherence*, and correspondingly *economy* are essential features of physical theories, and more widely of science?

This goal is desirable for at least two reasons. One is epistemological, concerning the nature of science. The second is related to students' motivation. This latter obsessive refrain – in these days of low or falling student numbers – often produces responses in terms of brilliant showmanship, or of telling exciting stories. Both components are most probably useful, but they are not sufficient. The pleasure that goes with abstraction deserves consideration, at the very least. This is especially true when a formal analysis, be it very “small”, is also elegant, that is when *coherence* and *economy* go hand in hand.

Another way of saying the same thing is to point to the value of maximising conceptual linkage. Here we give an example in physics of this kind of linkage, which has also strong implications for the choice of particular simple mathematical tools of analysis. This proposal [1] concerns two phenomena: the Doppler effect (discovered in 1842) and the non-uniform emergence times of Jupiter's satellites, a basis for Römer's discovery (1676). We will first describe a very simple and very commonly used approach to the Doppler effect, and then describe evidence that it can in fact be the source of some unwanted difficulties. Finally we suggest an alternative that avoids these problems and has the added merit of making a link between two seemingly unconnected phenomena, namely the Doppler effect and Romer's observations of the satellites of Jupiter.

The message of this paper is threefold. First, that seemingly small features of commonly used teaching approaches can produce unnecessary difficulties. Second, that seemingly minor but creative changes of point of view can offer substantial benefits and thirdly that amongst these benefits can be seeing connections between what appear to be very different parts of physics. In addition, however, we have to admit that such a change, however slight, often looks difficult to teachers, especially if they have not tried it.

The Doppler effect: a very simple approach

The very sensitive ears of a group of musicians detected, during a fête in Utrecht, the unusual pitch of the music played by trumpeters carried on a moving open railway carriage. This phenomenon, later completed by similar observations concerning light (W. Huggins 1868), was interpreted as the fact that periodic waves emitted by a source generated, as detected by a receiver, a signal of different frequency, if the receiver and source were in relative motion. So, the main actors in this story are waves. The Doppler effect concerns periodic signals, and is a matter of velocities and periods, or equivalently frequencies. However, it is very common to start explaining what happens by focusing on the maxima of amplitude of the wave, as if they were objects travelling in the propagation medium at a velocity c , the phase velocity. Let us call these entities “peaks”.

A further very common simplification is also adopted here: to consider only one dimension of propagation. How to extend this preliminary view to three-dimensional waves is not discussed here, as we have nothing particular to add on this question.

Simple as it is, this approach does not relieve us of the necessity of recalling that these “peaks” are not ordinary objects, that is, you cannot “launch” a “peak” by giving it an initial velocity with respect to the medium. If the source is moving with respect to this medium, the peak will not travel faster. A convenient way to symbolise this [1] is to imagine a conveyor belt moving at velocity c with respect to its support – the medium – with a source plotting ink dots on it at regular time intervals T_s . The source as well as the receiver may or may not be in relative motion with respect to the support of the conveyor belt. The positions of ink dots are only affected by the position of the source at the time they are plotted on the belt, whilst their subsequent travel with respect to the medium is always at velocity c , whatever the velocity of the source. It is rather intuitive that the possible motions of the source and of the receiver will affect the reception times of the “peaks”. These arrivals are periodic as well¹, but the corresponding period is different in case of non zero relative motion between source

¹ As far as V_R / c and V_S / c can be considered constant.

and receiver. A common variant of this analogy makes use of corks thrown in a river. Nothing new so far.

Now, going beyond intuition, let us see what can be calculated, still entirely classically.

A possible calculation is outlined in figure 1. Variations on it are possible, but what we will comment on below is a type of approach, and in this respect this example will suffice. The idea is to consider two successive “peaks” for (say) a source that is motionless with respect to the medium and a receiver that is moving away from the source, that is, its velocity with respect to the medium is V_R . The departure times are separated by T_S , and the travelled distances L_1 and L_2 are different due to the motion of the receiver in between. A simple calculation permits us to calculate the difference in arrival times as a function of the difference $L_2 - L_1$ between the distances travelled by the two “peaks”. This difference is itself linked to the velocity V_R of the receiver and to the time T_R elapsed between two reception times. It is given by $L_2 - L_1 = V_R T_R$. The well-known formula is then easily obtained:

$$(T_R - T_S) / T_R = V_R / c$$

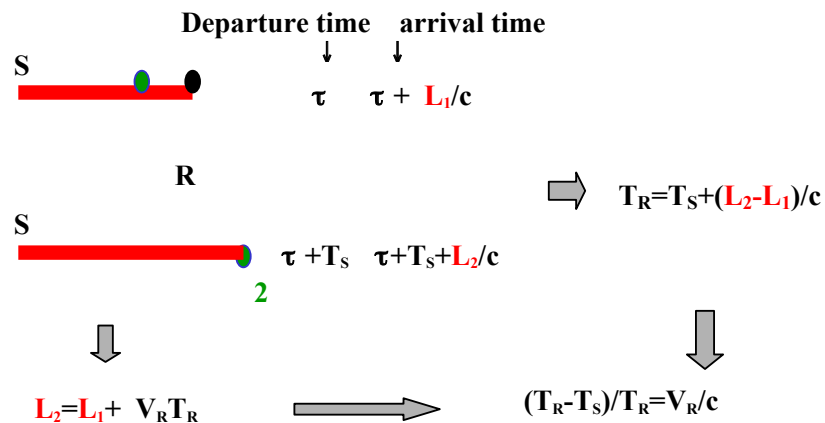

Figure 1. A mapping of a classical calculation about Doppler effect: the travel times for two successive “tops” are calculated, in relation to the distances travelled from source to receptor by each “top”, the receptor being in motion with respect to the medium. The difference between these travelled distances being simply expressed via the velocity of the receptor between two reception times, the result is easily obtained.

If now the receiver is motionless with respect to the medium but the source is moving with velocity V_S in the same frame of reference, a similar formula can be obtained using this kind of approach. It is not strictly identical but for small relative values of V_S and V_R with respect to c , to a first approximation the results are equivalent.

Concerning light in empty space, the theory of relativity leads to a different formula, and imposes a total equivalence on the two preceding cases, the only relevant factor being the relative velocity between source and receiver. To the first order of approximation, all these formulae can be written $\Delta T/T = V_{\text{relative}} / c$ where $\Delta T/T$ is the relative change in period between emission and reception and where V_{relative} , the relative velocity of the receiver with respect to the source, is positive if source and receiver are moving away from each other.

Why change? Some difficulties

If all this is so classical, why change anything in our teaching concerning this topic? In fact, as so often, students' difficulties pose unexpected problems. We investigated [1] students' understanding after teaching of this topic in third year at University (degree level). We found that about 70% of them (N=84) correctly predicted that two identical periodic signals emitted by sources of different velocities (with respect to the receiver) would generate signals of different frequencies at the receiver. So far, not bad. But unfortunately, only 50% of them were also able to predict that these frequencies would be equal if the sources had the same velocity but were at different distances from the receiver. Thus a non-negligible number of students responded as if the Doppler effect was a matter of distance.

Distance seen as a relevant factor: some possible reasons

Among the possible sources of such a difficulty, we see four kinds of potentially misleading situations. The first is linked to common experience, the second to images, the third to cosmology, the fourth to the elementary formal description recalled above.

“Think of the Doppler effect. Have you ever met such an effect in your life?” If such is the question, “wheeee-ououoummm” is quite often the answer. This is supposed to simulate a racing car passing by the observer-listener, and not coming directly towards him/her, which is important. The fact that the situation (happily for the observer's safety) is not one-dimensional, results in the radial velocity of the car varying with its distance (figure 2). And it is this radial velocity, i.e. the projection of the car's velocity on the direction from the observer to the car, which is relevant for the Doppler effect. There is a cosine of an angle present in the coupling between distance and radial velocity, hence the modulation of the pitch despite the constant value of the car's velocity.

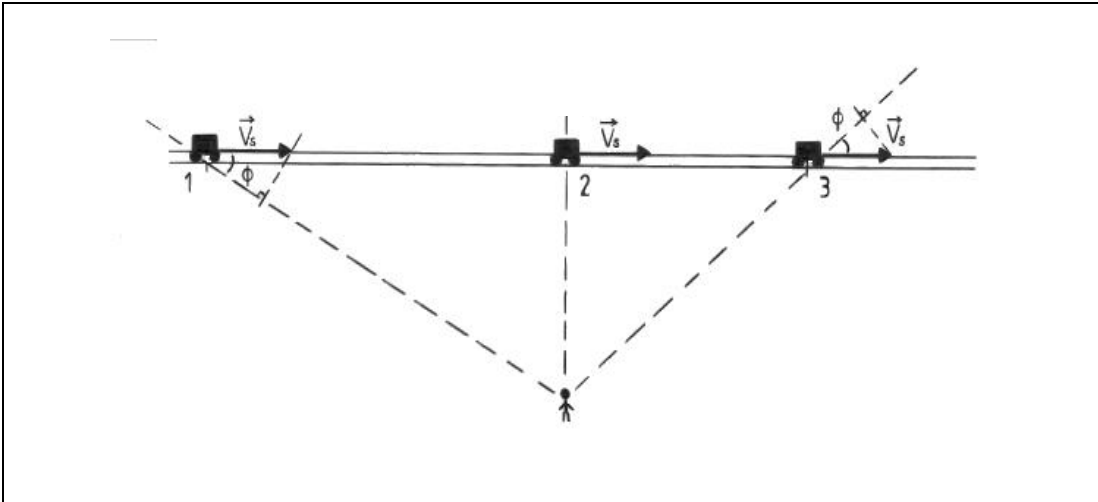

Figure 2. A common experience in which the radial velocity of a source (a car) and the distance between the source and the receiver are coupled [1].

This experience strongly suggests that the Doppler effect is directly connected to distance between source and observer, whereas the connection is actually quite indirect.

Our second example encompasses two aspects: images and cosmology. Figure 3 shows an image borrowed from a French book – it is by no means an isolated example.

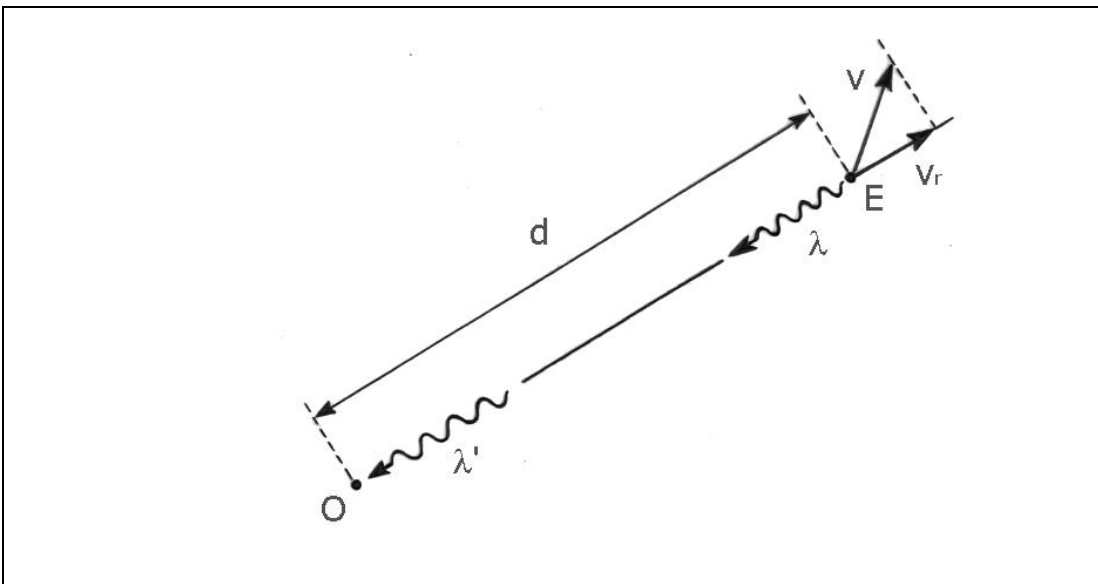

Fig. 3. An image about Doppler effect [2]

Many problems are raised by such an image: frames of references, times, impossible simultaneity of what is shown, a wavelength that seems to “know in advance” which receiver it will find, etc. Here, let us just underline how distance seems to be important in this picture. The investigation already mentioned [1] showed that this feature is very salient in this image, for teachers as well as for students. In fact, concerning cosmology,

it is very important, because the expansion of the universe couples distance and relative velocity of source and receiver. This fascinating theme being one of those most frequently presented in popular books and articles, with red-shift presented as arising from a Doppler effect, we should not be surprised if the Doppler effect is, so to speak, contaminated by the idea of distance in students' minds.

The fourth remark might seem of little importance compared to the preceding ones, but the rather different proposal which follows will, by contrast, highlight what we mean. In figure 1, the symbolic elements connected with a distance travelled from source to receiver have been coloured in red. The global "colour" of the calculation is fairly red, that is distances appear as cornerstones for the proposed reasoning, even if, as shown by the final formula, the Doppler effect is actually only a matter of velocities and periods, or equivalently frequencies.

Spotlighting the Doppler effect differently

To sum up, the Doppler effect concerns periodic signals and the case where there is a non-zero relative motion between source and receiver. Then, the signal at the receiver has a period different from that of the source. Distance between source and receiver is not directly relevant, although it is often considered as such. What to do to improve this situation?

To put it briefly, we propose to highlight the space-time structure of the problem, and the dependence of the Doppler effect on velocities and not on distance. To this end, we suggest using x/t graphs as in figure 4, still in one dimension. In the frame of reference of the medium, the rectilinear and uniform motions of the "peaks", of the source and of the receiver are easily represented on the graph.

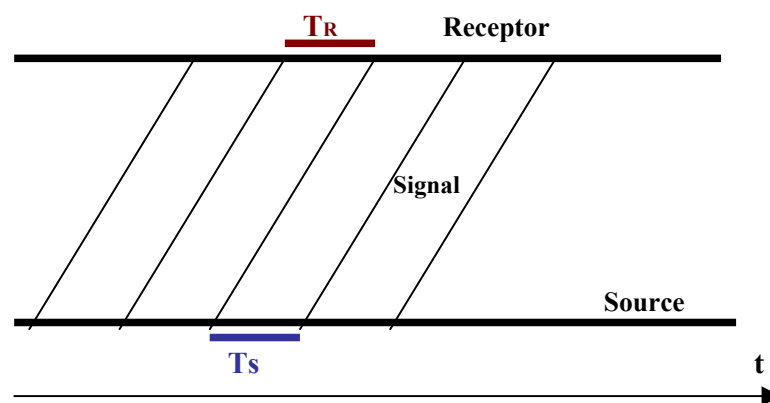

Figure 4. A graph to represent a one dimensional situation of propagation for a periodic signal, source and receptor being motionless with respect to the medium of propagation: distance between source and receptor is irrelevant.

For such a technique to be used profitably, the students must understand the meaning of the following elements:

- the linear function x/t associated with constant velocities
- the slope of the lines on the graph as giving the velocity of each corresponding motion
- the significance of the places where lines cross each other, representing the positions and times of emission and reception of the signal.
- intervals parallel to the t -axis, representing times between emission and reception of peaks

Thus, the two horizontal lines on the graph in figure 4 represent, in the frame of reference of the medium², a motionless source and receiver. The oblique lines represent the propagation of “peaks” emitted at regular time intervals by the source, with phase velocity c (note the identical slope of these lines). If you change the position of the receiver, it is clear that the intervals representing the period of reception will not be affected, from the properties of parallelograms. Slope, and only slope, matters.

Several cases can be dealt with, as, not surprisingly, we now play with the slope of the lines representing what happens to the source or to the receiver. Figure 5 shows that when these two lines are not parallel there is a difference between the period of reception and the period of emission, i.e. a Doppler effect occurs.

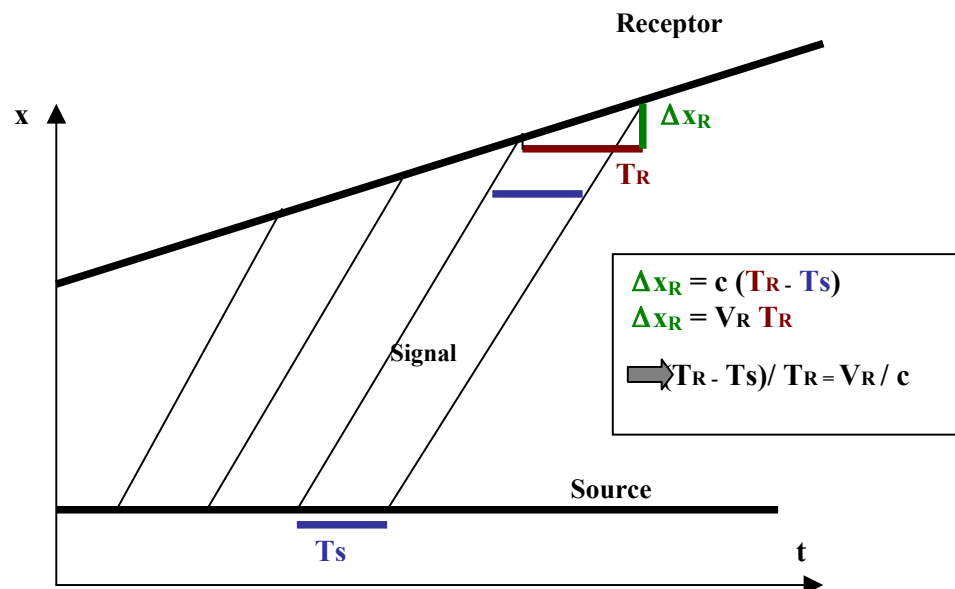

Figure 5. A graph to represent a one dimensional situation of propagation for a periodic signal, the source being motionless with respect to the medium of propagation, which is not the case of the receptor.

² In empty space, we can equivalently choose the frame of reference of the source or that of the receiver.

If this method happens to be criticised as *too qualitative* – a strange but not rare association of words – a calculation can easily be done. Let Δx_R be the distance travelled by the receiver between two reception times. This quantity can be written down as a function of the relevant time intervals:

$$\Delta x_R = (T_R) V_R = (T_R - T_S) c$$

The required Doppler formula follows immediately.

If this calculation had to be “coloured” as in figure 1, it would not be “red” at all: only a *change* of position of the receiver, *velocities* and *time intervals* are involved.

This method can be transposed to other particular cases, with the source moving or not with respect to the receiver or with respect to the medium, and towards or away from the receiver.

Although there is in principle nothing new in all this, the effect of such a presentation on students’ comprehension is likely to be somewhat different from that of the classical approach presented at the beginning of this paper. The relevance of the slopes of the graphs echoes that of the velocities in the phenomenon, and effectively excludes distance as a directly relevant variable. The importance of specifying the frame of reference adopted, and the space-time structure underlying this problem emerge as crucial. Profitable on the grounds of physics, such an analysis may also contribute to give meaning to what students learn in mathematics, especially concerning the linear function.

But we suggest another fruitful linkage.

Doppler and Römer: what do they have in common?

Imagine a search on the internet with the following key words: periodic signals, relative velocity (between source and receiver), modified periods. You might get Römer’s discovery in your net. It concerns the periodic appearance (or disappearance) of Jupiter’s satellites, for instance Io ($T_S = 42.5$ h), from behind this planet. The velocity of propagation of this signal towards the Earth is $c = 300\,000$ km/s.

The Earth is moving in Jupiter’s frame of reference, getting closer or farther twice a year, as it turns around the Sun. More precisely, the graph indicating its distance to Jupiter (figure 6) along the year is nearly a sinusoid, like the projection of a circular motion on a diameter.

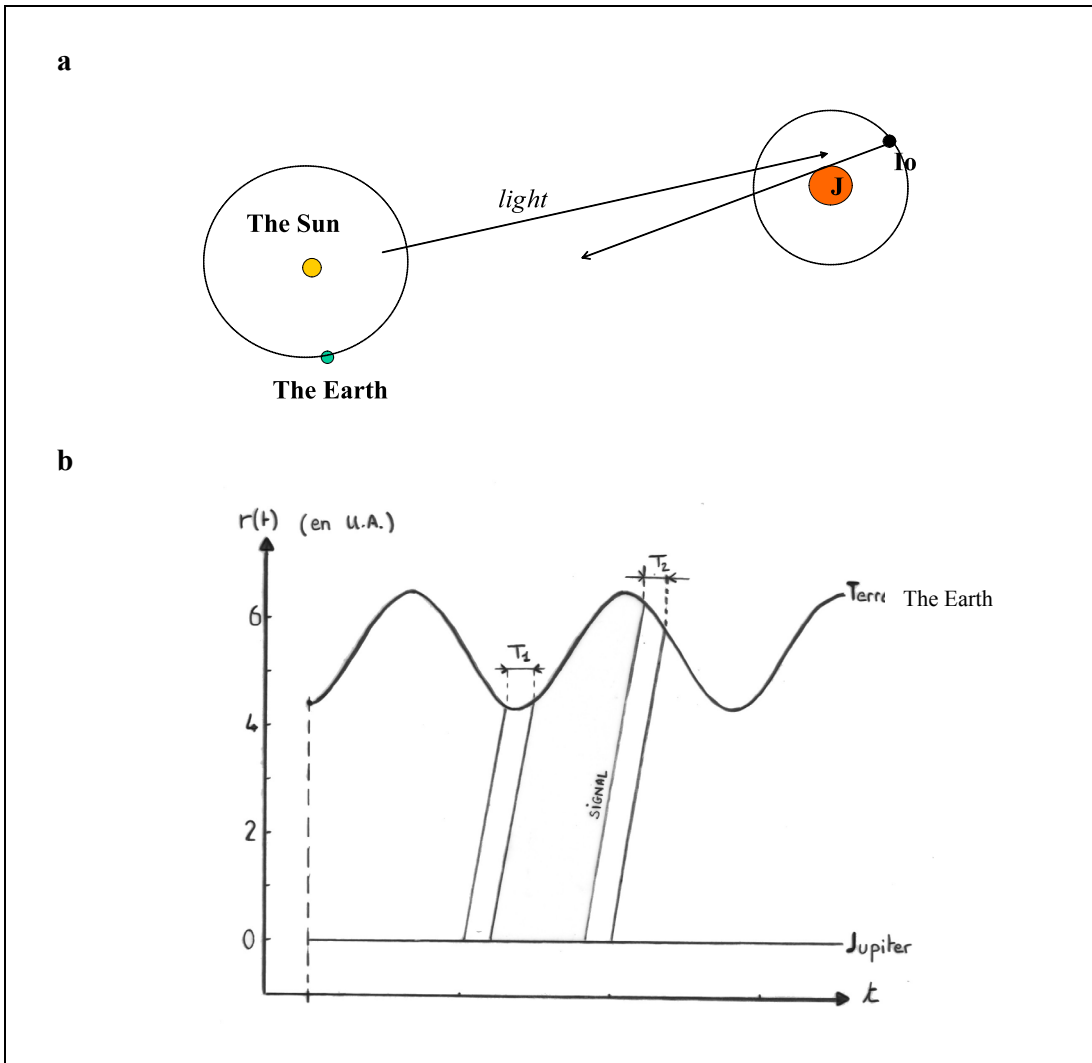

Figure 6. a: Jupiter's satellite IO and terrestrial observations of IO's emergence; b: positions of Jupiter and The Earth in the frame of reference of Jupiter in time. Equal distances $r(t)$ between the Earth and Jupiter correspond to different values of relative radial velocities. The extrema of this distance correspond to zero relative radial velocity.

The only difference with respect to the case analysed above is that the velocity of the Earth in Jupiter's frame of reference is not constant in time.

Then comes a method that is very classical in physics: take some small parts of the curve, treat them as lines, and see what happens. Figures 7 and 8 echo the "pure" cases explained in figures 4 and 5. When the Earth is at an extremum of distance, the relevant diagram looks like figure 4. Briefly put, there is no Doppler effect. When the Earth is at an intermediate distance, with its velocity exactly directed along the Jupiter-Earth line, there is a maximum shift in the observed period. This example fits very well in the

purpose adopted for this proposal, because radial velocity and distance are - so to speak - “anti-coupled”, this time.

The Earth at an extremum of distance

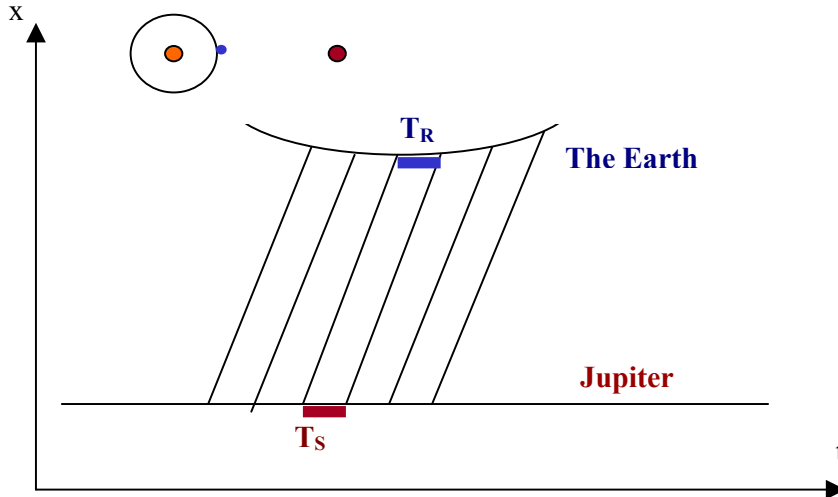

Figure 7. At an extremum of the distance between the Earth and Jupiter, the periodic emergence of a Jupiter’s satellite is observed without a Doppler effect

The Earth at an intermediate distance

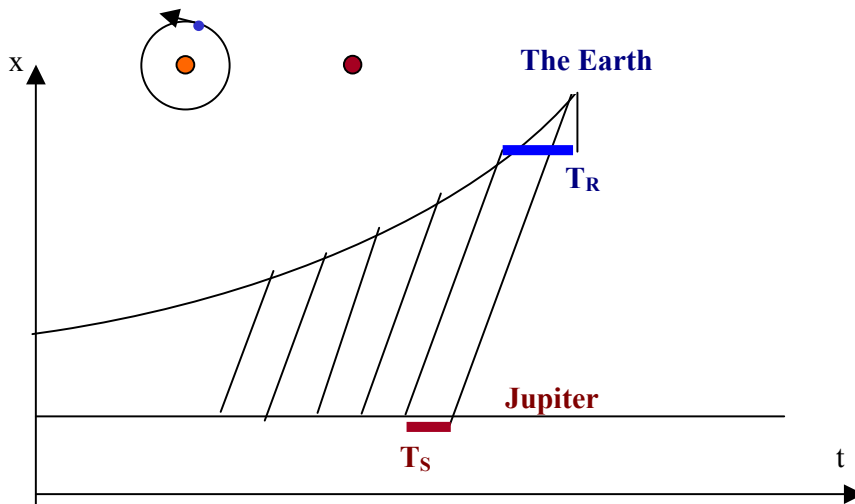

Figure 8. When the distance between the Earth and Jupiter has an intermediate value, the periodic emergence of a Jupiter’s satellite is observed with a Doppler effect.

One final remark, concerning this highlighting of Römer’s discovery. Römer’s essential contribution was not to calculate the speed of light but to show that it was not infinite. What would happen in figure 8 if this was the case? As shown in figure 9, the corresponding vertical lines on the graph determine equidistant points on the curve

showing the Earth's distance as a function of time, and the corresponding time intervals are exactly the period of emission T_S . Whatever the velocities of the source and of the receiver, there would not be any Doppler effect if the phase velocity of the signal was infinite. This essential idea is worth stressing when teaching Doppler effect, we think. The detour via Römer's story has the merit of highlighting this point, which constitutes a positive feedback of this surprising linkage.

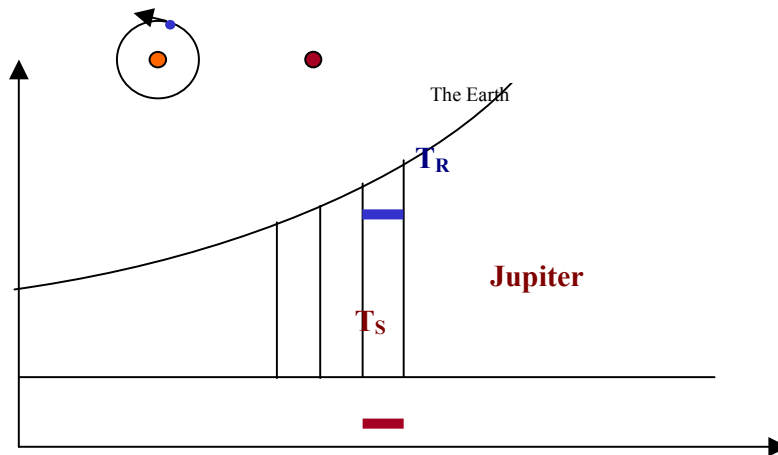

Figure 9. If the phase velocity was infinite, there would not be any Doppler effect, whatever the relative motion of the Earth and Jupiter

Some students' and teachers' reactions

A suggestion of this type may seem *a priori* elegant, intellectually gratifying and educationally well-argued, but it still requires an evaluation in term of students' and teachers' reactions. What has been done up to now is not a large inquiry, but some indications are available, which can be summed up as follows.

Small groups of students ($N= 10, 5, 8$) of third year university students have been taught a short sequence (one hour and a half, three successive years, for more detail see [1]). After two preliminary activities - one being a discussion about what they thought Doppler effect was and another organised around the critique of the image shown in figure 3 - the rest of the teaching sequence followed that described above. Comments collected show that understanding the graphs is not quite straightforward, but that once this threshold was passed, the students appreciated the possibilities offered: "It is clear that it is the slope that matters". The real triggering happened when the link with Römer's discovery was established. "It's brilliant", "Doppler effect should be called Römer effect!". The suggestive gesture of having both hands inclined then put vertically was a common response to the question "what happens if the velocity of propagation is infinite?".

Other groups of young trainee teachers were placed in the same learning situation and reacted similarly, sometimes with enthusiasm, sometimes with more emphasis on the difficulties of the graphs, and very often with pleasure and surprise when they realise how simply the nature of Römer’s discovery was clarified. Their response to a written consultation is summed up in table 1, as well as those of the group of degree students already mentioned. All were asked to rate from 1 (low interest) to 4 (strong interest) the value of three aspects of the sequence:

- using the graphs to understand that the relevant quantity were velocities and not distance,
- using the same graphs to conduct the proposed calculation,
- establishing a linkage between the two phenomena – “Doppler” and “Römer”.

They were asked to estimate this “interest” both for their own comprehension, and for possible students of last year in secondary school (*a priori*, that is, before they could actually try).

Table 1
Evaluation of the “Doppler and Römer” proposal by three groups of future teachers

Item ↓ rated by →	Degree Students		Secondary school trainee teachers*		University trainee teachers	
from 1 to 4 according to how well it aids understanding (4= a lot, 1 = not very much) for ...	N=8		N=38		N=10	
a) themselves						
b) students in last year in secondary school (grade 12)	a	b	a	b	a	b
1- Using graphs to show that it is relative velocity that matters, not distance.						
1 or 2	3	1	12	20	5	3
3 or 4	5	7	26	17	5	7
2- Using graphs to introduce the calculation of the shift in received period						
1 or 2	2	2	10	16	5	3
3 or 4	6	6	27	20	5	6
3- Deal with Römer’s discovery as a consequence of Doppler effect						
1 or 2	0	0	12	29	2	2
3 or 4	8	8	26	8	8	8

* a composite sample for two groups of same category

A look at table 1 suggests that there is a positive appreciation of the proposal, across the different groups. This is especially true when it comes to the last of the three points, the linkage between “Doppler” and “Römer”. It is seen as what made all the effort of interpreting the graphs worthwhile. This “investment” appeared as worthwhile, because

surprise and elegance were in play. Despite this satisfaction, some groups expressed reservations concerning the benefits to be expected for younger students. Sometimes, expectations on this point were marked with deep pessimism, as if it was thought that students at the end of secondary school were not capable of any such intellectual achievement and satisfaction. Although the most pessimistic group on this ground consisted of teachers who had not yet taught that category of students, we stress the existence of this kind of reaction because it has also been observed in other investigations [3] and because it may have lasting consequences for the teachers concerned.

Conclusion

With this example, we want to illustrate and underline some ideas that we think are important in teaching physics. Notably, a given content, commonplace and well-known as it may be, can be presented and staged for teaching in substantially different ways. As teachers, we have to choose what to spotlight – what "angle of vision" to adopt – in a given context and for specified teaching goals. And we have to do this on the basis of a thorough content analysis and of what we know of students' ideas and difficulties. We need also to be aware of how students' understandings can be influenced by the everyday and school environment.

The specific point addressed in this paper is the value of conceptual linkage, a characteristic feature of science and a good candidate to raise students' motivation. The spotlighting proposed for Doppler effect is in line with this goal and with the preceding remarks. The limited evidence so far seems to confirm our expectations as far as students' comprehension and interest are concerned. However, even if further work confirms the positive effects already observed, some teachers' *a priori* sceptical or pessimistic reactions have also to be taken into account, particularly in teacher training, if the merits of conceptual linkage, in this example and elsewhere, are to be widely accepted.

References

- [1] LEROY-BURY, J.L. & VIENNOT, L. 2003. Doppler & Römer : Physique et Mathématiques à l'œuvre. *Bulletin de l'Union des Physiciens*. Submitted
- [2] BOTTINELLI, L., BRAHIC, A GOUGUENHEIM, L., Ripert, J. & SERT, J. 1993. *La Terre et l'Univers* – Coll. Synapses, Paris : Hachette Éducation – encadré p.137 « l'effet Doppler – Fizeau ».
- [3] VIENNOT, L. 2003. *Teaching Physics*, Dordrecht: Kluwer Academic Publishers.